

**Government of India
Ministry of Communications & IT
Department of Telecommunications
1110, Sanchar Bhawan, 20 Ashoka Road, New Delhi**

No. 32-8/2009-EW

Dated: 29.06.2009

To

All IPs of USOF (Phase-I) Sites

Subject: Pilot projects on renewable energy in USOF (Phase-I) Sites – Extension of last date of submission of EOI

Sir,

The last date of submission of EOI document is extended to 31st July 2009.
All other terms and conditions shall remain unchanged.

Yours faithfully,

(Mukesh Wadhwa)
ADG (Elect.)

Department of Telecom**Subsidy Support from USO Fund to Establish the Use of Renewable Energy in the Telecom Sector on Pilot Project basis in Rural and Remote Areas.****1. Background**

1.1 Telecommunications has been recognized as one of the prime support services needed for rapid growth and modernization of various sectors of the economy. However, in achieving a wider spread of such initiatives in rural India the dismal state of rural electrification is a major challenge. There are villages where the grid has not even reached, and even electrified villages do not receive reliable and stable supply. The poor power quality substantially increases the Capex and Opex of telecom installations and also leads to unsatisfactory quality of services.

1.2 The problem of inadequate electricity supply is experienced at the telecom service providers' installations as well as at the customers' premises. At the telecom installations, the problem is overcome using diesel generators. These generators, however, entail transportation and storage of diesel which is a major logistics problem in rural/remote area, besides the environmental pollution caused by the generators. At customers' premises the electricity supply problem is partially mitigated by the use of battery inverters or ac-dc converters. The battery however remains only partially charged if the electric supply is very unreliable.

1.3 Decentralized distributed generation technologies based on renewable energy resources such as solar photo voltaic (SPV)/ Wind Turbine Generators (WTG) address the above barriers to a large extent and are therefore considered as emerging alternate power solution for the telecommunications net-works.

1.4 Telecom Service Providers across the country have been using renewable energy sources, especially solar installations for powering individual mobile infrastructure sites; however the effectiveness of renewable energy for the larger power requirement of a shared mobile infrastructure site under rugged rural and remote area conditions is yet to be established.

2. Objective of the Renewable Energy Pilot Project Scheme.

2.1 The objective of this scheme is to establish the *technical feasibility* and *financial viability* for solar/ solar-wind hybrid renewable energy systems in shared mobile infrastructure sites in rural/remote areas.

2.2 The Universal Service Obligation Fund under Department of Telecom has been established to provide access to telegraph services to the people in rural and remote areas of the country at an affordable and reasonable cost. The USOF has come into effect from 1.4.2002. The Indian Telegraph (Amendment) Act, 2003 giving statutory status to the Universal Service Obligation Fund (USOF) was passed in December, 2003. The Rules for administration of the Fund known as Indian Telegraph (Amendment) Rules 2004 were notified on 26.03.2004. The Indian Telegraph Act was amended on 29.12.2006 to enable support for mobile services, broadband connectivity, general support for mobile services, broadband connectivity, general infrastructure and pilot projects. The Rules for administration of the Fund under this Act, Indian Telegraph (Amendment) Rules 2006 have been published on 17.11.2006. Stream VI of the said Rules provides for induction of new technological developments in the telecom sector in rural and remote areas. Under this Stream, Pilot Projects shall be undertaken to establish new technological developments in the telecom sector, which can be deployed in such areas and shall be supported with the approval of the Central Government.

2.3 The USOF Administration (hereinafter referred to as 'USOFA') is considering extending financial support to the Part 'A' players who are signatories to USOF Agreement No.30-148/2007-USF(Part-A) (hereafter referred to as 'the Infrastructure Provider' or 'IP') in selected states (refer Appendix A) from amongst the sites finalized for USOF's Mobile Infrastructure Phase I project in rural and remote areas. I. The participation of the IP in this scheme shall be contingent upon the written consent of the Part 'B' players(hereafter referred to as 'Universal Service Providers' or 'USPs') that had been selected by USOFA to share the relevant sites for the Mobile Infrastructure scheme Phase I and who have entered into Agreement Nos. 30-148/2007-USF(Part-BI) /30-148/2007-USF(Part-BII) with USOF.

2.4 The IP applying to participate in this scheme shall specify the intellectual property rights (IPR) liabilities, if any, associated with the Pilot Project at the outset so that this aspect shall not create a hindrance at a subsequent stage. Financial repercussions, if any, of the IPR aspect shall also be clearly stated by the IP. Any liabilities accruing despite the foregoing shall be dealt by the IP using his resources.

3. Scope of Work.

3.1 The IP shall undertake the Pilot Project for renewable energy installations broadly conforming to the specifications (Appendix B) and execute the same to establish the technical feasibility and financial viability of use of renewable energy and demonstrate the same to USOFA / Certifying Agencies / Telecom Service Providers (TSPs).

3.2 This pilot project would involve the IP providing requisite renewable energy infrastructure with the assistance of a renewable energy vendor who shall provide technological support and execute the installation work as directed by the IP, and the USOFA shall provide limited financial assistance as specified.

3.3 Upper ceiling limit for subsidy support shall be Rs. 50 lakhs per Pilot Project.

4. Responsibilities of the Infrastructure Provider.

4.1 It shall be the overall responsibility of the Infrastructure Provider to execute the Pilot Project in association with the identified renewable energy vendor within the time frame specified.

4.2 The Vendor for Hybrid(Solar cum Wind) installations shall be chosen from amongst the approved list of vendors available at www.mnes.nic.in on the MNRE site. For Solar installations suitable vendors may be selected either from amongst the list of vendors on MNRE website at www.mnes.nic.in or otherwise.

4.3 The IP shall be responsible for maintaining technical and financial data as specified from time to time by the USOFA during the execution of the Project and make them available in the format/form desired. (Annexure-VI)

4.4 The IP shall meet all the infrastructural requirements such as land, security, necessary clearances etc. for execution of the Pilot Project.

4.5 The IP shall be responsible for understanding the technical and economic implications of operating renewable energy installations in the rural and remote areas and for a critical and thorough evaluation of business development scenarios and assessment of risks. This shall include change in configuration from the individual installation of power plant and battery by the USPs in the previous arrangement of USOF Phase I sites to a centralized DC power arrangement by the IP to ensure optimal use of the BTS site area for installation of SPV and WTG systems. (Refer Annexure III). The necessary changes shall be effected by the IP with the consent of the concerned USPs without any cost or liability to USOF in this regard.

4.6 The IP shall have to complete the Pilot Project within a specified period from the date on which the agreement is signed. This time frame for completing the pilot project shall be mutually fixed by the USOFA in consultation with the selected applicants. The outer limit for completion of a Pilot Project shall not be more than 12 weeks from the date on which the agreement is signed.

4.7 The renewable energy installation and its underlying technology as demonstrated in the pilot project would have to be functional for at least 12 months before complete subsidy support is released so that various aspects of the technology and its impact can be studied and established.

4.8 For studying and establishing various aspects of the demonstrated technology and its impact, the IP shall get the completed Project tested and evaluated by the Designated Agency/Agencies as approved by the USOFA.

4.9 IP shall be responsible for organizing a Seminar for DOT, USOF, TEC, TRAI, all interested TSPs and other parties on the technology demonstrated in the Pilot Project.

5. **Eligibility Condition**

5.1 The applicant should be a selected Part A player IPs for Phase I Sites in the states as listed in Appendix A. These are the IPs who are signatories to USOF's Agreement 30-148/2007-USF(Part-A) for mobile Infrastructure in the states mentioned in Annexure.

5.2 The IP shall have to obtain the written consent of the three USPs sharing the IP's site for participation in the pilot project including the aspect of centralized DC power supply and its distribution arrangement (as per Annexure III) to USPs. The IP must also obtain written consent from the USPs for necessary modification in the SLA signed between the IP and USPs for incorporating a mutually agreeable cost sharing arrangement towards renewable energy power supply

6. **Type of Project to be Supported**

6.1 The type of pilot projects which could be undertaken include solar/solar-wind hybrid as per specifications defined in this document.

7. **Funding and Subsidy Support**

7.1 The subsidy support from the Government would be up to a maximum of seventy five-percent (75%) of the project cost (after accounting for accelerated depreciation benefits available for such projects.) subject to an upper limit of Rs 50 Lakhs. However, the reasonableness of cost projected for subsidy support will be decided by USOF.

7.2 The IP thus supported by USOF may charge the three service providers for the power generated from the subsidized renewable energy installations as per mutually agreed cost sharing arrangement during the validity of the Mobile Infrastructure Agreement 30-148/2007-USF(Part-A) signed between the IP and the USOF. A suitable clause to this effect shall be incorporated in the Service Level Agreement signed between the IPs and USPs and the same shall be certified by the IP.

8. Processing of the applications

8.1 The project proposals shall be short listed in a time bound manner by scrutinizing all the applications.

8.2 Presentation may be required to be made to the USOF by short listed applicants on the Pilot Projects giving details of the technology, funds requirement, timing, site selection etc.

8.3 The quantum of subsidy within the prescribed limit, and its phasing shall be decided by the USOF.

8.4 Based on techno-financial evaluation the USOF shall decide the Pilot projects to be supported.

8.5 Initially the number of such pilot projects shall be limited to 20. However, this limit may be reviewed subsequently.

9. Evaluation Criteria

9.1 Applications will be evaluated for their technological, commercial and financial merits. The evaluation criteria would include:

- Preference shall be given to off grid sites
- The soundness, quality and technological merit of the proposal
- Conformity to minimum prescribed technical specifications
- The potential for wide spread application and the benefits expected to accrue from commercialization
- The reasonableness of the proposed cost of the project
- The cost per Unit of renewable energy generated,

10. Agreements

10.1 A bilateral agreement shall be signed between the IP and the USOF Administration as applicable specifically for the pilot project.

10.2 The clauses in the Agreement may cover, inter alia, monitoring the project, inspection, examination of records, payment schedules, termination, resolution of disputes, etc.

10.3 Liability of each of the parties shall be spelt out clearly in the Agreement.

10.4 A specific payment schedule will be incorporated in the agreement. A part of the subsidy payment will be made upon successful completion and certification of the renewable energy installation by a Designated Authority to be decided by USOFA. The balance payment shall be made after twelve months of successful running of the renewable energy installation, as certified by the agency/agencies selected by USOFA for the purpose.

10.5 To facilitate monitoring of the project and project completion, the IP shall be required to submit returns in the prescribed formats for at least a period of ten months post commissioning of the renewable energy project.

11. **Submission of applications**

11.1 The USO Fund shall receive the application for subsidy support for Pilot projects till 1600 Hrs. of 30.06.2009.

11.2 The applicant is requested to carefully study the instructions before filling in the application form. The Financial Bid must be placed in a separate envelope and this shall be opened only for technically qualifying Applicants.

11.3 The application with supporting documents may be sent, in six copies along with the soft copy to:

The ADG (Electrical)

Department of Telecommunications,

1110, Sanchar Bhawan, 20 Ashoka Road, New Delhi-110 001.

Ph.no. 91-11-23738688, Fax 91-11-23372328

E-Mail : adgdot@rediffmail.com

11.4 USOFA reserves the right to amend these Pilot Project Funding Guidelines, without notice at any date before the signing of an Agreement with the selected IP.

APPENDIX A

**LIST OF STATES WHERE PILOT PROJECTS ARE TO BE IMPLEMENTED
AND TYPE OF PROJECT TO BE UNDERTAKEN.**

Sl No.	(1)	(2)	(3)	
	State	Project Type	Eligible IP	
			BSNL(No of Clusters)	Private(No of Clusters)
1.	Andhra Pradesh	Hybrid	BSNL(2)	GTL(4), HESL(2)
2.	Bihar	Solar	BSNL(4)	-----
3.	Chhattisgarh	Solar	BSNL(3)	NITL(2)
4.	Gujarat	Hybrid	BSNL(1)	-----
5.	Haryana	Solar	BSNL(1)	-----
6.	Himachal Pradesh	Solar	BSNL(2)	RCL(1)
7.	J&K	Solar	BSNL(2)	-----
8.	Jharkhand	Solar	BSNL(2)	RCIL(1)
9.	Karnataka	Hybrid	BSNL(4)	-----
10.	Kerala	Solar	-----	RCIL(1)
11.	M.P	Hybrid	BSNL(10)	-----
12.	Maharashtra	Hybrid	BSNL(8)	VESL(1)
13.	Orissa	Hybrid	BSNL(3)	RCIL(1)
14.	Punjab	Solar	BSNL(1)	-----
15.	Rajasthan	Solar	BSNL(4)	-----
16.	Tamil Nadu	Hybrid	BSNL(4)	-----
17.	Uttaranchal	Solar	BSNL(2)	-----
18.	U.P(E)	Solar	BSNL(3)	GTL(2)
19.	U.P(W)	Solar	BSNL(1)	QTL(1)
20.	W.Bengal	Solar	BSNL(2)	-----

Note: Only one pilot project shall be taken up in each state

Technical Specifications

1. Solar Photo Voltaic (SPV) Module

- 1.1 Solar Photo Voltaic (SPV) module array to be of high efficiency made of crystalline silicon solar PV cells. The cells are hermetically sealed under toughened high transmission glass to produce highly reliable weather resistant modules.
- 1.2 Power output guarantee offered for the SPV module shall not be for less than 15 years in any of the climatic condition prevailing in India. For minimum stipulated life, the derating factor of 0.5% per year of SPV system/module rated power is permissible. The SPV module/system shall deliver at least 92.5% of its rated power in 15th year also.
- 1.3 Individual Solar module rating shall not be less than 125 Wp at STC (Higher ratings can be used) and shall meet following minimum requirement :

Efficiency of cell $\eta_c \geq 14\%$

Efficiency of module $\eta_m \geq 13\%$

Fill factor shall be better than 70%.

- 1.4 The SPV modules shall satisfy the environmental test conditions as per IEC-68-2-2 Test Bb, IEC-68-2-1 Test Ab, IEC-68-2-14, IEC-68-2-38, IS 9000 (PART 16), Clause 16.0 of QM- 333, & IEC : 61215
- 1.5 Insolation- Main insolation at any panel kept at optimum tilt at place where the solar panel is to be used shall be 4.5 Kw hour per m² per day.

2. Module Mounting Structure

- Structure shall be designed in accordance with the latitude of the place of installation. The steel for the mounting structure shall be as per IS 2062: 1992 and withstands the wind speed of 200 KM/hour.
- The design/drawings of the mounting structure shall be supplied.
- The array structure shall be so designed that it will occupy minimum space without sacrificing the output of SPV panels.
- Structure shall have suitable anti theft measures to prevent easy removal of Solar Modules.

3. Array Junction Box

- The junction box shall be made of FRP/Thermoplastic with IP65 protection.
- Metal oxide arrestors shall be provided inside the array junction boxes.

4. Battery Bank :

- The battery shall be of 2500 AH (1250 AHx2) 48V (24 cell) VRLA GEL type (deep-cyclic), suitable for SPV application i.e. slow rate of charge and discharge.

5. Charge controller unit :

Typical pictorial representation of Charge controller unit is as under:

(NOTE : Diagram was taking a lot of memory space and hence was not allowing the email to be transmitted. Hence the diagram has been removed from the soft copy. The same is available in the hard copy of EOI document)

Charge controller unit shall manage power supply employing grid/ diesel generator (SMPS of TEC approved make), SPV and Wind Power. It shall provide for the necessary DC power supply to the battery/ load and also protect battery bank from over charge, deep discharge, reverse polarity and short circuit, thereby ensuring that the electrical characteristics are met for optimum performance and reliability. It monitors all the functions of SPV power source and SMPS (some on charge controller along with SMPS and all other on the SMPS). It provides for termination for output of the SPV array, output of wind power, output of the SMPS (through a switch), load and battery. It shall house all the necessary alarms, monitoring, control and also provide lightning and surge protection devices (SPV side on the charge controller itself, while SMPS side lightning and surge protective devices on the SMPS). Its design will ensure optimal energy transfer from the SPV system using MPPT (Maximum Power Point Tracking) technique

6. D.C.Distribution panel

The D C power from the battey bank shall be distributed to the three BTS service providers through a suitable D.C. Distribution panel having one incomer and four outgoings (including one spare) having suitable rating isolators & fuses. The panel shall have provision for lightning arrestor, battery reverse protection, earthing etc. Each outgoing feeder shall have Visual Indicators, energy meter, Voltmeter and Ammeter.

7. Environmental Requirements:

The system shall be designed to work satisfactorily under all the environmental conditions. SPV modules, charge controller,

mounting structure and batteries shall be capable of working in a saline atmosphere in coastal areas and shall be free from any corrosion at any period of time in compliance with the requirements of relevant clauses of QM-333.

8. Wind Generator

The turbine and its associated circuitry is expected to supply 42 to 58 volts regulated DC to the telecommunications load at BTS. The wind turbine generator of 4-5 KW capacity shall conform to MNRE approved specifications. The Control System shall be PLC / Micro processor based having the rated output voltage of 42-58 V D.C. The Emission standard shall be as per the TEC standard TBRR/F/GQR-GN/33.TEC/2004 (Part) dt. 11.01.08.

9. Cabling & interconnections

- All cables shall be confirming to IS 694
- Only PVC Copper cables shall be used
- Size of cables shall be so selected to keep the voltage drop and losses to the minimum

10. Earthing

The array structure shall be grounded properly using adequate number of grounding kits. All metal casing/shielding of the plant shall be thoroughly grounded to ensure safety of the power plant.

APPLICATION FORM

No. 30-41/2006-USOF (Part I)
Department of Telecom
Office of the Administrator, USO Fund

Application Form to establish use of non-conventional energy to power shared BTS sites in Telecom Sector on Pilot Project basis in Rural and Remote areas

(Separate Annexures may be used for providing detailed information wherever required)

1. Tower ID (As per USOF List)
- 2a. Name of the Applicant Infrastructure Provider
- 2b. Names of the Associated USPs
 - (i)
 - (ii)
 - (iii)
- 2c. Name of Renewable Energy Vendor
- 2e. Complete Correspondence Address of Applicant:
 - a) Registered Office with
Telephone numbers/ fax/ e-mail
 - b) Administrative Office with
Telephone numbers/ fax/ e-mail
3. Cost of the project (with complete justification and item wise break up of funding sought):
4. Proposed Project Location (State/District/Block/Village etc.):
- 5a. Likely duration of the Project:
- 5b. Chart indicating the implementation schedule:
- 5 Whether applied for financial assistance for the same/ similar project from any other institution/ agency?
If so, the details and status thereof
- 6 Details of the clearances/ permissions etc. required from Government/ DoT, if any:

7 Declaration in the enclosed proforma

8. Attatchments:

- A. Certificate of willingness from USPs as per Annexure I
- B. Certification of Technical Checklist duly filled up as per Annexure II
- C. Technical details of Project indicating layout plan to be submitted in Annexure III
- D. Financial Bid as per Annexure IV/Annexure V (as applicable)

DECLARATION

(To be signed by the Applicant
Or its authorized agent)

The particulars given in the Application Form and its Attachments are true and correct. No material has been suppressed or concealed. It is certified that I/ We have read the guidelines, terms and conditions governing the scheme and undertake to abide by them on behalf of my/ our organization/ company. The financial assistance, if provided, shall be put to the declared use.

APPLICANT/ AUTHORIZED SIGNATORY

(With seal of the company)

Date:

Place:

(Strike out whichever is not applicable)

ANNEXURE I

CERTIFICATE

(To be signed by each of the USPs
Or their authorized agent)

It is hereby certified that having understood terms and of participating in USOF's renewable energy pilot project scheme; M/S..... has no objection to the IP, M/s..... of the site at.....(village/district/state)bearing USOF's Tower ID No.participating in the above mentioned scheme and to the consequent provision power from the renewable energy installations set up under this scheme as per the terms and conditions set out in DOT Circular No.dated..... An SLA has been signed with the IP M/sfor suitable cost sharing towards renewable energy power supply. It is understood that the individual SMPS/battery sets rendered spare due to centralized DC power supply may have to be reutilised at a later date.

APPLICANT/ AUTHORIZED SIGNATORY

(With seal of the company)

Date:

Place:

(Strike out whichever is not applicable)

ANNEXURE - II

Name and address of BTS site :

Name and address of the Vendor :

Sl.No.	Item	Equipment offered
1.0	Solar Photo Voltaic(SPV) Module	
1.1	Make & Type of SPV Module	
1.2	Rating of individual Solar module at STC (not less than 125 WP)	Yes / No
1.3	Efficiency of cell ($\geq 14\%$)	Yes / No
1.4	Efficiency of module ($\geq 13\%$)	Yes / No
1.5	Area of Module m xm
1.6	Area of panel	m ²
1.7	Design life of the SPV module (not less than 15 years)	Yes / No
2.0	Module Mounting Structure	
2.1	Whether Drawing/design of mounting structure attached	Yes / No
2.2	Whether the mounting structure is designed to withstand the wind speed of 200KM/hour	Yes / No
2.3	Whether suitable anti theft measures provided to prevent easy removal of Solar Modules	Yes / No
3.0	Array Junction Box	
3.1	Whether it is with IP65 protection	Yes / No
4.0	Battery Bank	
4.1	VRLA GEL Type (deep cyclic)	Yes / No
4.2	Capacity of battery 2500 AH (2 nos. of 1250 AH) 48 V (24 Cell) provided	Yes / No
4.3	Capacity of battery at C/20 rate of discharge	% of its rated capacity

5.0	Charge controller unit	
5.1	Whether logic for integration of solar, grid, wind, and diesel generator power is in built	Yes / No
5.2	Lightning and surge protection devices provided	Yes / No
5.3	Whether design ensures optimal energy transfer from the SPV system using MPPT (Maximum Power Point Tracking) technique	Yes / No
5.4	Whether controller has PWM regulation	Yes / No
5.5	Whether provision for storing and retrieving performance data for a period of 1-2 years and its remote monitoring is made	Yes / No
5.6	Whether detailed circuit diagram& logic of control unit attached	Yes / No
6.0	SMPS	
6.1	SMPS rating	A
6.2	Whether SMPS is inbuilt in charge control unit or a separate unit	
7.0	Wind Turbine Generator	
7.1	Whether conforms to MNRE approved specification	Yes / No
7.2	Capacity	KW
7.3	Whether Type test certificate from accrediting laboratory in accordance with IEC 61400-2 is furnished	Yes / No
7.4	Tower height	m
7.5	Weight of WTG	Kg

Important Notice/ Information for IPs:

1. Preference shall be given to off grid sites
2. Availability of at least 160 sq metres of land (south facing) for solar panels must preferably be ensured for installation of 10 K Wp Solar panel. If 160 square metres of land is not available suitable arrangement would have to be made for accommodating 10 K Wp solar panel through elevated structure etc.

ANNEXURE III

TECHNICAL DETAILS AND LAYOUT PLAN

Guidelines:

The individual installation of power plant and battery by Service Providers in the previous arrangement is to be changed to centralized DC power arrangement by the Infrastructure Provider to ensure optimal use of the BTS site area for installation of SPV and WTG systems.

The powering system shall comprise of solar power, wind power (where feasible), grid supply (if available), and DG of suitable capacity. A typical schematic powering arrangement is as under:

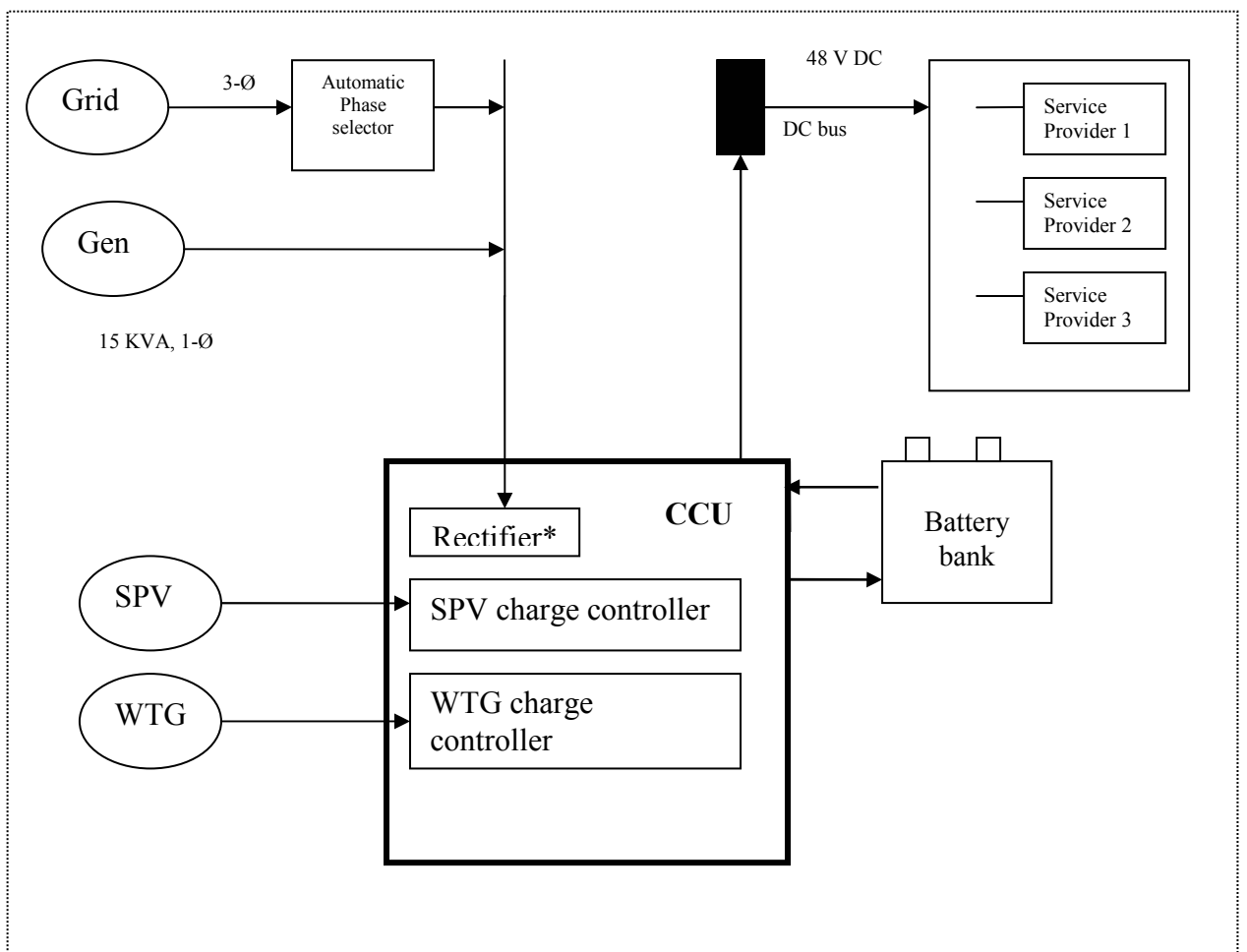

* Rectifier can be outside CCU module

Land available : In a typical USOF Phase-I shared rural BTS site of 400 sq mtr, having a tower, 15 KVA DG set & 3 BTS shelters, approximately 160 sq mtr clear space may be available for SPV. 10 KWp SPV is proposed to be accommodated, as shown under

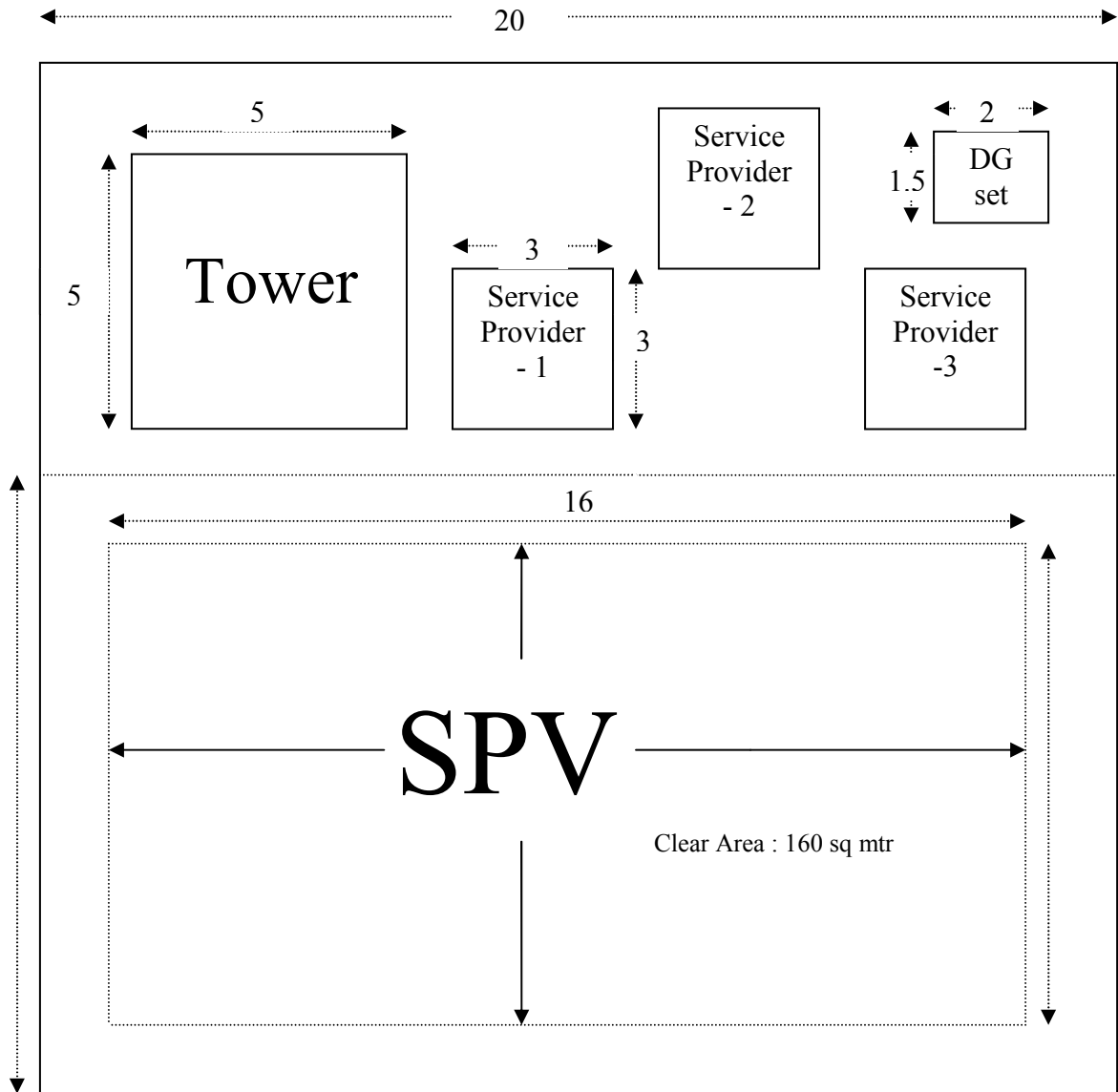

South facing

Requirement

- Bidder may design an ideal layout for installation of SPV panel either at ground level or at an elevated structure, or combination of both as the case may be, as per the site

availability taking into consideration optimal efficiency of generation, easy maintenance and best possible utilization of space. Layout design with dimensioning is to be attached

- Bidders while quoting may also specifically indicate as to whether higher capacities (> 10 KWp) of SPV can be accommodated at the USOF shared BTS site.

ANNEXURE IV

**Name Of Work : Pilot project for Establishment of Renewable Energy Use
in Shared Mobile Infrastructure Sites**

Financial Bid

(To be placed in separate sealed envelope)

S.No.	Item	Qty	Unit	Rate (Rs.lakhs)	Amount (Rs.lakhs)
1	SITC of following rating Solar Power Generation System capable of generating 48 V DC Power with 2500 AH battery backup consisting of SPV panel, array mounting structure, battery bank, battery rack, Charge control unit with solar, grid & generator integrated feature with remote monitoring, protections, DC distribution board, suitable cabling for interconnections, earthing, suitable weather proof, well ventilated shed made of novapan to house battery bank, charge control unit, DC distribution board etc complete as required as per the attached specifications. 10KWp SPV, 2500AH Battery (2x 1250AH)		Nos.		
Firms may quote Prorata rates for following items for additional requirement if any. These shall not be taken into consideration for evaluation of bids. a) SPV (per KWp) Rs..... b) Battery (per AH) Rs..... c) SMPS (50 A Module) Rs.....					

Rates and amount to be quoted both in figures as well as in words

ANNEXURE V

**Name Of Work : Pilot project for Establishment of Renewable Energy Use
in Shared Mobile Infrastructure Sites**

Financial Bid

(To be placed in separate sealed envelope)

S.No.	Item	Qty	Unit	Rate (Rs.lakhs)	Amount (Rs.lakhs)
1	SITC of following rating Solar-Wind Hybrid Power Generation System capable of generating 48 V DC Power with 2500 AH battery backup consisting of SPV panel, array mounting structure, battery bank, battery rack, Charge control unit with solar, wind, grid & generator integrated feature with remote monitoring, protections, DC distribution board, suitable cabling for interconnections, earthing, suitable weather proof, well ventilated shed made of novapan to house battery bank, charge control unit, DC distribution board etc complete as required as per the attached specifications. 10KWp SPV, 4-5 KW WTG 2500AH Battery (2x 1250AH)		Nos.		
<p>Firms may quote Prorata rates for following items for additional requirement if any. These shall not be taken into consideration for evaluation of bids.</p> <p>a) SPV (per KWp) Rs..... b) WTG (per KW) Rs..... c) Battery (per AH) Rs..... d) SMPS (50 A Module) Rs.....</p>					

Rates and amount to be quoted both in figures as well as in words

ANNEXURE-VI**FEEDBACK DATA PERFORMA (Weekly/Monthly)**

FROM.....TO.....

Location	State	Latitude	Longitude

Infrastructure Provider's Name	:
Service Provider – I	:
Service Provider - II	:
Service Provider - III	:

A. SOLAR/SOLAR – WIND HYBRID SYSTEM

SOLAR ARRAY CAPACITY : KWp

WTG CAPACITY :KW

Sl. No.	Description	Unit	SPV	WTG
1	Total Units Generated during the period	KWH		
2	Average daily units	KWH		
3	Energy to Battery Bank during the period	AH		
4	Average daily Energy to Battery Bank	AH		

B. DIESEL GENERATOR(DG)

Sl. No.	Description	Unit	Previous data of other similar sites (Only DG running)	Present (With RE Power system)
1	DG Capacity	KVA		
2	DG Run Time	Hrs.		
3	Average Daily DG Run Time	Hrs.		
4	Fuel Consumption /day	ltrs		
5	Total energy Generated – DG during the period	KWH		

